

ZUMMO 

ZUMMITO Z05



PROGRAMADOR Y CONTADOR DIGITAL
PROGRAMMER AND DIGITAL COUNTER



KIT COPAS GRANDES
KIT LARGE CUPS

www.zummo.es **ZUMMO** 
INNOVACIONES MECÁNICAS, S.A.



Sistema de Calidad certificado
Nº Reg.: 12 100 15585 TMS



Nº de Registro del Certificado
12 104 15585 TMS



REF. C15



REF. C25



REF. C35



REF. C65



REF. C75

- El exprimidor automático más compacto y versátil
- Adecuado para cualquier tipo de instalación dado su reducido tamaño
- Programador y contador digital de frutas exprimidas
- Rampa de alimentación con capacidad para 8 a 10 frutos
- Cesta superior de almacenamiento de frutas. Facilita la recarga de la rampa de alimentación. Añade vistosidad a la máquina
- Incluye de serie un segundo kit de exprimido para gran calibre, admitiendo frutas de 75 a 90 mm. Por ello, es el único exprimidor en el mercado capaz de exprimir naranjas y limones de gran calibres y pomelos pequeños
- Kit de exprimido para pequeños calibres, ideal para mandarinas o naranjas y limones pequeños (45 a 60 mm) (opcional)
- Filtro de acero inoxidable
- Bandeja antigoteo y cubetas recoge-cortezas
- Cuerpo del exprimidor totalmente en acero inoxidable

(*) Opcional / Optional

- *The most compact and versatile automatic juicer on the market*

- *Suitable for any kind of fixture, thanks to its compact size*

- *Programmer and digital squeezed fruit counter*

- *8 to 10-fruit capacity feeding ramp*

- *Upper fruit storage basket simplifies the task of loading the feed ramp, while beautifying the machine*

- *Standard equipment includes juicing kit for large-sized fruit. Capable of handling fruit from 75 to 90 mm (3" to 3 1/2"), making it the only juicer on the market able to squeeze large-sized oranges and lemons as well as small grapefruit*

- *Juicing kit for small-sized fruit – ideal for tangerines, as well as small oranges and lemons (45 to 60 mm) (1 3/4" to 2 1/3") (optional)*

- *Stainless steel filter*

- *Anti-drip grille and peel bins*

- *Entire juicer cabinet made of stainless steel*



KIT MANDARINA / TANGERINE KIT (*)

accesorios Z05
accessories

CARACTERÍSTICAS TÉCNICAS

VOLTAJES DISPONIBLES

220-230 V - 50/60 Hz.
110 V - 50/60 Hz.
240 V - 50 Hz.

MOTOR MONOFÁSICO 0.33 CV

CONSUMO 0,25 Kw.

PESO: 43 Kg.

CAPACIDAD DEL ALIMENTADOR: 9 a 12 frutas.

FRUTAS POR MINUTO: 10

TAMAÑO DE LA FRUTA
60 a 80 mm

PROTECCIÓN: Protección por triple sensor automático de seguridad
Protección térmica
Protección por bloqueo motor

TECHNICAL CHARACTERISTICS

VOLTAGE:

220-230 V - 50 /60 Hz.
100 V – 50/60 Hz.
240 V – 50 Hz.

MOTOR: Single phase 0.33 CV

CONSUMPTION: 0,25 Kw.

NET WEIGHT: 43 Kg.

FEEDER CAPACITY: 9 to 12 fruits

FRUITS PER MINUTE: 10

FRUIT DIAMETER:
2 1/3" to 3 1/2"

SECURITY: Safety cut-out triple detector
Motor over-heat protection
Protection against blocked motor

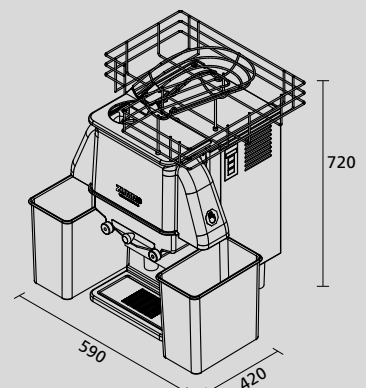

MEDIDAS
SIZES